

Smart Cameras for Embedded Machine Vision

NI 17xx Smart Cameras **NEW!**

- Real-time machine vision
- High-quality monochrome VGA (640x480) or SXGA (1280x1024) CCD image sensors
- High-performance embedded processors
- Isolated 24 V digital I/O
- Dual gigabit Ethernet ports
- RS232 serial support
- Support for industrial protocols
- Expansion analog and digital I/O through NI Compact FieldPoint and CompactRIO
- Built-in NI direct drive lighting controller for current-controlled LED light heads¹
- Quadrature encoder support¹

¹Not supported by NI 1722 Smart Camera

Recommended Software

- Vision Builder for Automated Inspection (included) or
- LabVIEW and the LabVIEW Real-Time Vision Development Bundle

Recommended Accessories

- C-mount lens
- Power and I/O cables
- Mounting bracket



Overview

NI 17xx Smart Cameras simplify machine vision by analyzing images directly on the camera with a powerful, embedded processor capable of running the entire suite of NI vision algorithms. You can use these cameras in a variety of applications including part location, defect detection, code reading, and assembly verification. The combination of the onboard processor with a charge-coupled device (CCD) image sensor provides an easily distributed, all-in-one vision system that transmits inspection results along with or in place of raw images. Housed in a rugged metal case designed for use in industrial applications, all NI Smart Cameras offer built-in I/O, multiple industrial protocols, built-in Web servers, and many other features. You can configure NI Smart Cameras with the included NI Vision Builder for Automated Inspection (AI) software or program the camera with LabVIEW Real-Time.

Flexible Industrial I/O

To communicate results to other industrial devices, NI Smart Cameras offer built-in digital I/O and support both Ethernet- and serial-based industrial protocols such as Modbus TCP. NI Smart Camera digital I/O lines are optoisolated for direct connectivity with industrial devices such as triggers and actuators. All NI Smart Cameras offer two optoisolated digital inputs and two optoisolated digital outputs.

To simplify Ethernet-based communication, NI Smart Cameras include two gigabit Ethernet ports. With one port connected to an industrial network to report inspection results, the other port can directly communicate with programmable automation controllers (PACs) such as NI CompactRIO or Compact FieldPoint, with industrial devices such as programmable

logic controllers (PLCs), or with human machine interfaces (HMIs). All NI Smart Cameras include an RS232 serial port and 5 and 24 V lighting strobe outputs that you can use for synchronization with third-party lighting controllers.

NI Smart Cameras, with the exception of the NI 1722, include quadrature encoder support for synchronizing inspections with linear and rotary drive systems. This feature simplifies timing in complex applications where consistency is critical to system success.

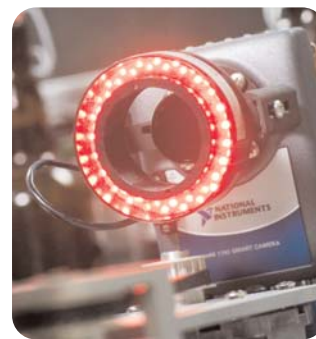

Direct Drive Lighting

To directly illuminate objects under the camera, NI Smart Cameras feature direct drive lighting. Lighting controllers can be costly additions to machine vision applications. NI Smart Cameras have a built-in lighting controller so you can directly drive lights from the camera itself,

lowering costs and simplifying wiring. The built-in direct drive lighting controller can provide a constant DC current of 500 mA or a strobed current of up to 1 A. With strobed lighting, you can increase the intensity produced by up to four times without harming the light head. Most current-driven LED light heads work with the NI Smart Camera's direct-drive feature (this feature is not included on the NI 1722).

Smart Cameras for Embedded Machine Vision

Camera Comparisons

National Instruments offers a variety of smart cameras to meet a breadth of machine vision application needs.

All NI Smart Cameras process images using onboard PowerPC processors. In higher-performance models, a Texas Instruments digital signal processor (TI DSP) acts as a coprocessor to boost the performance of specific algorithms. The image sensors inside all NI Smart Cameras are charge-coupled devices (CCDs).

NI 1722 Smart Camera – Powered by a 400 MHz PowerPC processor; features a VGA (640x480) resolution CCD image sensor that can acquire images up to 60 fps.

NI 1742 Smart Camera – Powered by a 533 MHz PowerPC processor; acquires VGA resolution (640x480) monochrome images at up to 60 fps.

NI 1744 Smart Camera – Uses the same 533 MHz processor as the NI 1742 but features a higher-resolution CCD that acquires images of 1.3 megapixels (1280x1024); with higher resolution, you can inspect objects for smaller defects and make measurements with four times the resolution of previous NI Smart Cameras.

NI 1762 Smart Camera – Offers a 720 MHz TI DSP coprocessor alongside the 533 MHz PowerPC, making it possible to run specific algorithms up to four times faster with no changes to the application software (works well for engineers needing higher performance for pattern matching, optical character recognition, and datamatrix code reading); contains the same VGA resolution (640x480) image sensor found in the previous NI Smart Cameras.

NI 1764 Smart Camera – Provides the 1.3 megapixel image sensor found in the NI 1744, and the 720 MHz TI DSP coprocessor found in the NI 1762; ideal for high-speed manufacturing.

Hardware Comparison		NI 1722	NI 1742	NI 1744	NI 1762	NI 1764
Processor Configuration	Processor	400 MHz PowerPC	533 MHz PowerPC	533 MHz PowerPC	533 MHz PowerPC	533 MHz PowerPC
	Coprocessor	–	–	–	720 MHz DSP	720 MHz DSP
Memory	System memory	128 MB	128 MB	128 MB	128 MB	128 MB
	Firmware and job storage	128 MB	128 MB	128 MB	128 MB	128 MB
Image Sensor	Resolution	640x480	640x480	1280x1024	640x480	1280x1024
	Image size	1/3 in. CCD	1/3 in. CCD	1/2 in. CCD	1/3 in. CCD	1/2 in. CCD
	Pixel depth	8-bit	8-bit	8-bit	8-bit	8-bit
	Color	–	–	–	–	–
	Acquisition rate (frames per second)	60 fps	60 fps	13 fps	60 fps	13 fps
	Partial image acquisition	✓	✓	✓	✓	✓
	Display	Web interface	Web interface	Web interface	Web interface	Web interface
I/O Options	TTL I/O	1	1	1	1	1
	Isolated digital input	2	2	2	2	2
	Isolated digital output	2	2	2	2	2
	Encoder input	–	✓	✓	✓	✓
	I/O breakout	✓	✓	✓	✓	✓
	Ethernet I/O support	✓	✓	✓	✓	✓
Communication Options	Ethernet	2X 10/100/1000	2X 10/100/1000	2X 10/100/1000	2X 10/100/1000	2X 10/100/1000
	RS232	✓	✓	✓	✓	✓
Lighting	External light control	✓	✓	✓	✓	✓
	Integrated light control and power	–	✓	✓	✓	✓
Application Development	Included configuration software	Vision Builder AI	Vision Builder AI	Vision Builder AI	Vision Builder AI	Vision Builder AI
	Programmable software option	LabVIEW	LabVIEW	LabVIEW	LabVIEW	LabVIEW
Operation Temperature Range	Camera	0 to 45 °C	0 to 45 °C	0 to 45 °C	0 to 45 °C	0 to 45 °C
Housing Material		Metal	Metal	Metal	Metal	Metal

Table 1. NI Smart Camera Hardware Comparison

Smart Cameras for Embedded Machine Vision

Software

Unmatched Scalability

All NI Smart Cameras include the NI Vision Builder for Automated Inspection (AI) configurable vision application development environment so you can build and deploy complete machine vision applications quickly and easily. Vision Builder AI applications are based on an easy-to-use state diagram model. With this model, you can configure sophisticated inspections that include loops and branches without programming. Vision Builder AI also features all of the steps you need to develop complete machine vision systems, including advanced triggering, acquisition from data acquisition devices, communication with HMIs and PLCs, and control of digital I/O lines.

For more advanced applications, NI Smart Cameras are also full-featured NI LabVIEW Real-Time targets. This adds the power of LabVIEW and the world-class algorithms in the NI Vision Development Module to this new platform. Other modules supported in LabVIEW Real-Time, such as the LabVIEW Control Design and Simulation Module, also work with NI Smart Cameras.

NI vision software makes it easy to move between a configurable environment and a programming environment. With Vision Builder AI, you can create an inspection and easily convert it to LabVIEW code. If you want to use Vision Builder AI but need a bit more flexibility than it offers, you can also create custom steps for Vision Builder AI using LabVIEW.

Hardware Scalability

The NI vision hardware platform ranges from PCI- and PXI-based systems to compact vision systems to the sensor itself with NI Smart Cameras. This entire range of hardware works with both LabVIEW and Vision Builder AI. This means you can design and prototype your machine vision algorithms using an off-the-shelf machine vision camera connected to an NI frame grabber and deploy that same application to an NI Smart Camera with minimal changes to your LabVIEW code or Vision Builder AI inspection.

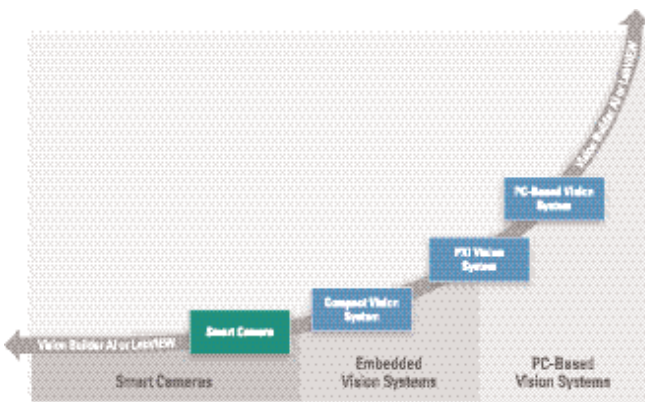
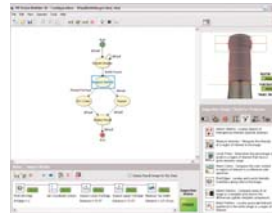

Figure 1. With the scalability of NI vision software, you can develop your code on a PC, prototype on an NI Compact Vision System, and deploy to an NI Smart Camera without ever changing your application development environment.

Software – Configure or Program



Vision Builder for Automated Inspection

Vision Builder (AI) is a configurable machine vision development environment that requires no programming. With the Vision Builder AI, you can:

- Build, benchmark, and deploy complete machine vision applications without programming
- Configure more than 40 powerful machine vision tools including pattern matching, OCR, and particle analysis
- Create custom user interfaces for display and control purposes
- Host user interfaces on a built-in Web server
- Communicate with industrial protocols over serial and Ethernet



LabVIEW Real-Time Vision Development Bundle

The NI LabVIEW Real-Time Vision Development Bundle includes all the software you need to program a real-time machine vision application

with LabVIEW. You must purchase LabVIEW separately.

The bundle includes:

- LabVIEW Real-Time Module
- LabVIEW Application Builder
- NI Vision Development Module

The Vision Development Module, a library of image processing and machine vision functions, includes the Vision Assistant, an interactive prototyping environment that generates ready-to-run code. The Vision Development Module delivers:

- Hundreds of image processing functions including pattern and geometric matching, OCR, bar code readers, object classification, and particle analysis
- Tools to enhance images, check for presence, locate features, identify objects, and gauge parts
- Fast application prototyping and code generation with the Vision Assistant
- Subpixel accuracy down to 1/10 of a pixel and 1/10 of a degree

Smart Cameras for Embedded Machine Vision

National Instruments vision software includes hundreds of image processing and analysis functions. A subset of the tools available in the Vision Development Module and Vision Builder AI are shown below.

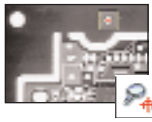

Pattern and Geometric Matching

Learn and locate objects and patterns in your images. The National Instruments patented matching algorithms locate patterns fast with very high accuracy.



Optical Character Recognition/Verification

NI OCR functions use a trainable OCR algorithm specifically designed to identify and verify all types of fonts, characters, and symbols despite poor and inconsistent image quality.



Particle Analysis

Use particle analysis to detect connected regions or groupings of pixels in an image and make selected measurements of those regions. Choose from more than 80 unique measurements that return data in both real-world and pixel values.



Color Inspection

Color matching quantifies which colors and how much of each color exist in a region of an image and uses this information to check if another image contains the same colors in the same ratio.

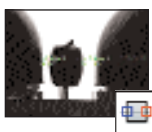

Edge Detection

Use the edge detection tools to identify and locate discontinuities in the pixel intensities of an image. Find edges to align, measure, or detect features in the image.



Object Classification

Classification is a tool for identifying an unknown object by comparing its significant features to a set of features that represent known samples.

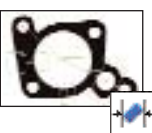

Gauging

Use dimensional measurement or gauging tools to obtain quantifiable, critical distance measurements such as distances, angles, areas, line fits, circular fits, and counts.



Bar Code Reader and Grader

Read 1D bar codes as well as 2D codes like Data Matrix and PDF 417. You can decipher codes applied through ink jets, thermal transfer, laser etching, or dot peen.

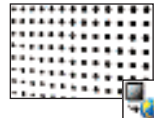

Spatial Calibration

Using spatial calibration functions, you can calibrate your image to take accurate, real-world measurements from images, regardless of camera perspective or lens distortion.

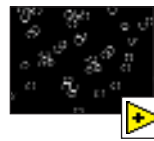
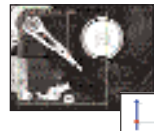

Image Arithmetic and Logic Functions

Operators perform basic arithmetic and logical operations on images. Use operators to add, subtract, multiply, and divide an image with other images or constants.



Coordinate Systems

Set up coordinate systems to ensure that all your measurements move with the object within the field of view.

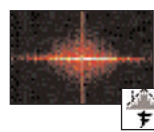

Image Filters and Frequency Analysis

Frequency filters, such as the fast Fourier transform (FFT), alter pixel values with respect to the periodicity and spatial distribution of the variations in light intensity in the image.



Image Segmentation

NI vision software comes with several options to segment and partition images into related components. Segmentation is an important part of many imaging applications that need to extract certain features or objects in order to process them further.



Golden Template Comparison

Find defects in an image by comparing a perfect (golden) sample to all subsequent samples. Golden template comparison detects surface defects, label misprints, and overall quality issues.

Smart Cameras for Embedded Machine Vision

Smart Camera Accessories



Lighting

All NI Smart Cameras except for the NI 1722 provide direct connectivity to many current-controlled LED light heads, including those below. Additional lighting is available from Advanced Illumination (www.advill.com).

Back light (red)	780221-01
Ring light (red)	780222-01
Linear array (red)	780223-01
Spot light (red)	780224-01

Lenses

NI Smart Cameras work with any standard C-mount lens, including the lenses below supplied by Computar.

8 mm, F1.4, megapixel, Computar	780024-01
12 mm, F1.4, megapixel, Computar	780025-01
16 mm, F1.4, megapixel, Computar	780026-01
25 mm, F1.4, megapixel, Computar	780027-01

Cables and Power Supplies

NI 17xx unshielded screw terminal breakout with 2 m cable	780261-01
NI Smart Camera I/O accessory.....	780443-01
Desktop power supply, 24 V, 63 W	780237-01
DIN-rail mount power supply	778805-90
15-pin high-density D-Sub male to flying leads, 5 m	197818-05
Ethernet cables, twisted pair	
1 m	182219-01
5 m	182219-05
10 m	182219-10

Smart Camera Mounting

¼ in.-20 tripod adapter	780239-01
Mounting bracket	780240-01

Expansion I/O and HMIs

If your applications need more I/O than NI Smart Cameras provide, you can easily connect expansion I/O over standard Ethernet. Compact FieldPoint and CompactRIO are two popular NI platforms for expansion I/O. Both of these platforms are built on real-time architectures, ensuring the determinism needed for many industrial applications. CompactRIO also features a built-in field-programmable gate array (FPGA) for precise timing and synchronization. Communication to both of these platforms is simplified with the use of shared variables in LabVIEW or Vision Builder AI. For more information on these platforms, visit ni.com/compactfieldpoint or ni.com/compactrio.

For interfacing options, NI offers a full suite of touch panel HMIs. With the LabVIEW Touch Panel Module, you can develop custom HMI applications for Windows CE touch panel devices. Other options include Windows XP HMI devices that can run the entire LabVIEW development environment. Or simply target NI Smart Cameras and other PAC devices through a Web browser with the Web server technology available on these hardware platforms. For more information on HMI options from NI, visit ni.com/hmi.

Ordering Information

NI 1722 Smart Camera with Vision Builder AI	780146-01
NI 1742 Smart Camera with Vision Builder AI	780147-01
NI 1744 Smart Camera with Vision Builder AI	780403-01
NI 1762 Smart Camera with Vision Builder AI	780306-01
NI 1764 Smart Camera with Vision Builder AI	780402-01

Additional Software

NI LabVIEW	776670-09
NI LabVIEW Real-Time Vision Development Bundle	779324-03

BUY NOW!

For complete product specifications, pricing, and accessory information, call 800 813 3693 (U.S.) or go to ni.com/vision.

Smart Cameras for Embedded Machine Vision

Specifications

>> For complete specifications, see the *NI 17xx Smart Camera User Manual* at ni.com/manuals.

Image Sensor

Sensor	Sony CCD
Resolution	VGA (640 x 480), SXGA (1280 x 1024)
Max frame rate	60 fps (VGA), 13 fps (SXGA)
Sensor size	1/3 in. (VGA), 1/2 in. (SXGA)
Pixel size	7.4 x 7.4 μm (VGA), 4.65 x 4.65 μm (SXGA)
Sensor readout	Progressive scan
Bits per pixel	8 bits, 256 gray levels
Scanning mode (VGA)	1/2 scan – 640 x 240 1/4 scan – 640 x 120
Scanning mode (SXGA)	1/2 scan – 1280 x 512 1/4 scan – 1280 x 256
Binning	1x2 – 640 x 240 (VGA), 1280 x 512 (SXGA)
Min exposure time	36.3 μs (VGA), 76.7 μs (SXGA)
Exposure time increment	31.2 μs (VGA), 71.6 μs (SXGA)

Processor Characteristics

Processor	
NI 1722	400 MHz Freescale PowerPC
NI 1742/1744	533 MHz Freescale PowerPC
NI 1762/1764	533 MHz Freescale PowerPC and 720 MHz Texas Instruments DSP
Memory	128 MB
Nonvolatile program storage	128 MB
Image/data storage	Unlimited through FTP or Ethernet hard drive

Lighting Connectivity

NI 1722	
5 and 24 V external strobe	Programmable duration
NI 1742, 1744, 1762, 1764	
5 and 24 V external strobe	Programmable duration
Direct drive lighting	500 mA DC, 1 A strobed

I/O Connectivity

Digital input	2 channels optoisolated 24 V
Digital output	2 channels optoisolated 24 V
Ethernet	2 ports (10/100/1000 Mb/s)
RS232 serial	Up to 230.4 kb/s
Quadrature encoder	Phase A/Phase B, no index (not available on NI 1722)

Power Requirements

Main supply voltage	24 VDC, +20%, -15% (IEC 1311)
Max current	
NI 1722	450 mA
NI 1742, 1744, 1762, 1764	800 mA (with direct drive lighting)

Physical Specifications

Lens mount	C-mount
Dimensions	11.765 by 8.58 by 5.06 cm
Weight	525 g

Safety and Compliance

Safety

This product is designed to meet the requirements of the following standards of safety for electrical equipment for measurement, control, and laboratory use:

- IEC 61010-1, EN 61010-1
- UL 61010-1, CSA 61010-1

Note: For UL and other safety certifications, refer to the product label or visit ni.com/certification, search by model number or product line, and click the appropriate link in the Certification column.

Electromagnetic Compatibility

This product meets the requirements of the following EMC standards for electrical equipment for measurement, control, and laboratory use:

- EN 61326 (IEC 61326): Class A emissions; Basic immunity
- EN 55011 (CISPR 11): Group 1, Class A emissions
- AS/NZS CISPR 11: Group 1, Class A emissions
- FCC 47 CFR Part 15B: Class A emissions
- ICES-001: Class A emissions

Note: For EMC compliance, operate this product according to the documentation.

CE Compliance

This product meets the essential requirements of applicable European Directives, as amended for CE marking, as follows:

- 2006/95/EC; Low-Voltage Directive (safety)
- 2004/108/EC; Electromagnetic Compatibility Directive (EMC)

Note: Refer to the Declaration of Conformity (DoC) for this product for any additional regulatory compliance information. To obtain the DoC for this product, visit ni.com/certification, search by model number or product line, and click the appropriate link in the Certification column.

Waste Electrical and Electronic Equipment (WEEE)

EU Customers: At the end of their life cycle, all products must be sent to a WEEE recycling center. For more information about WEEE recycling centers and National Instruments WEEE initiatives, visit ni.com/environment/weee.htm.

Mechanical Drawings

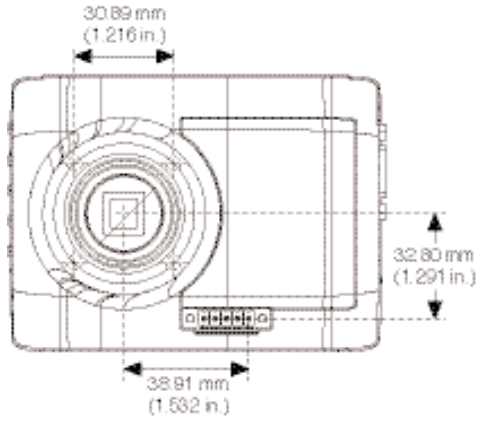

Figure 2. Camera Front

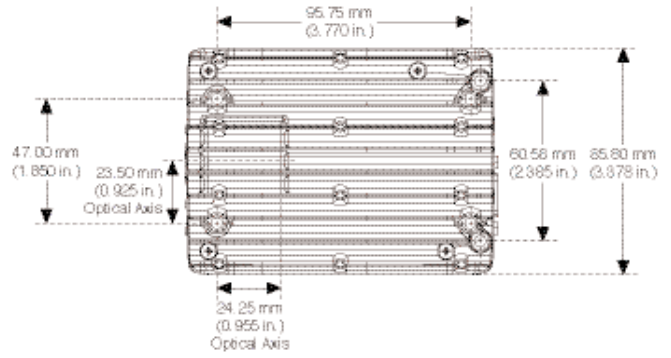

Figure 3. Camera Back

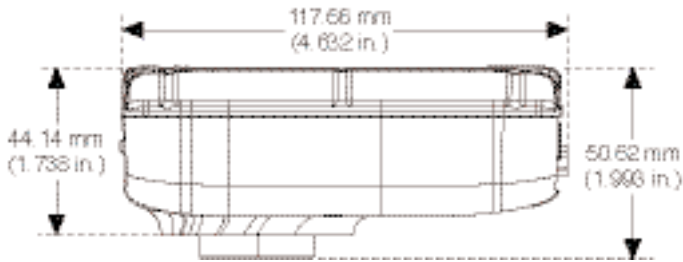

Figure 4. Camera Side

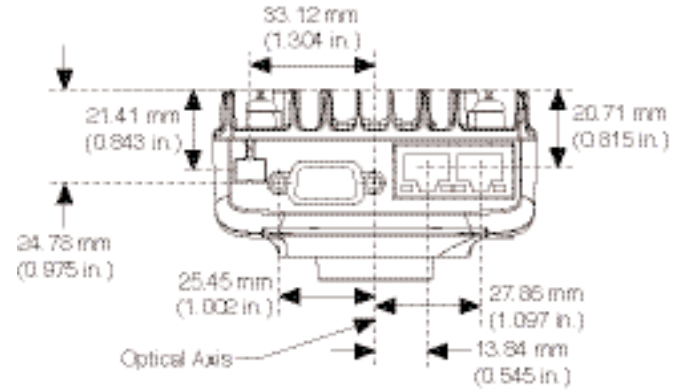
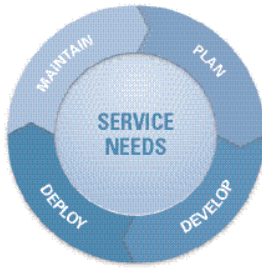

Figure 5. Camera Bottom

NI Services and Support



NI has the services and support to meet your needs around the globe and through the application life cycle – from planning and development through deployment and ongoing maintenance. We offer services and service levels to meet customer requirements in research, design, validation, and manufacturing. Visit ni.com/services.

Training and Certification

NI training is the fastest, most certain route to productivity with our products. NI training can shorten your learning curve, save development time, and reduce maintenance costs over the application life cycle. We schedule instructor-led courses in cities worldwide, or we can hold a course at your facility. We also offer a professional certification program that identifies individuals who have high levels of skill and knowledge on using NI products. Visit ni.com/training.

Professional Services

Our NI Professional Services team is composed of NI applications and systems engineers and a worldwide National Instruments Alliance Partner program of more than 600 independent consultants and

integrators. Services range from start-up assistance to turnkey system integration. Visit ni.com/alliance.



OEM Support

We offer design-in consulting and product integration assistance if you want to use our products for OEM applications. For information about special pricing and services for OEM customers, visit ni.com/oem.



ni.com • 800 813 3693

National Instruments • info@ni.com

Local Sales and Technical Support

In offices worldwide, our staff is local to the country, giving you access to engineers who speak your language. NI delivers industry-leading technical support through online knowledge bases, our applications engineers, and access to 14,000 measurement and automation professionals within NI Developer Exchange forums. Find immediate answers to your questions at ni.com/support.

We also offer service programs that provide automatic upgrades to your application development environment and higher levels of technical support. Visit ni.com/ssp.

Hardware Services

System Assurance Programs

NI system assurance programs are designed to make it even easier for you to own an NI system. These programs include configuration and deployment services for your NI PXI, CompactRIO, or Compact FieldPoint system. The NI Basic System Assurance Program provides a simple integration test and ensures that your system is delivered completely assembled in one box. When you configure your system with the NI Standard System Assurance Program, you can select from available NI system driver sets and application development environments to create customized, reorderable software configurations. Your system arrives fully assembled and tested in one box with your software preinstalled. When you order your system with the standard program, you also receive system-specific documentation including a bill of materials, an integration test report, a recommended maintenance plan, and frequently asked question documents. Finally, the standard program reduces the total cost of owning an NI system by providing three years of warranty coverage and calibration service. Use the online product advisors at ni.com/advisor to find a system assurance program to meet your needs.

Calibration Services

NI recognizes the need to maintain properly calibrated devices for high-accuracy measurements. We provide manual calibration procedures, services to recalibrate your products, and automated calibration software specifically designed for use by metrology laboratories. Visit ni.com/calibration.

Repair and Extended Warranty

NI provides complete repair services for our products. Express repair and advance replacement services are also available. We offer extended warranties to help you meet project life-cycle requirements. Visit ni.com/services.

